

BATTERY/STARTER/GENERATOR SERVICE

CONTENTS

	page		page
BATTERY	1	SPECIFICATIONS	11
GENERATOR	8	STARTER	3

BATTERY

GENERAL INFORMATION

This first section will cover Battery replacement and service procedures only. For Battery diagnostic procedures, refer to Group 8A, Battery/Starting/Charging Systems Diagnostics.

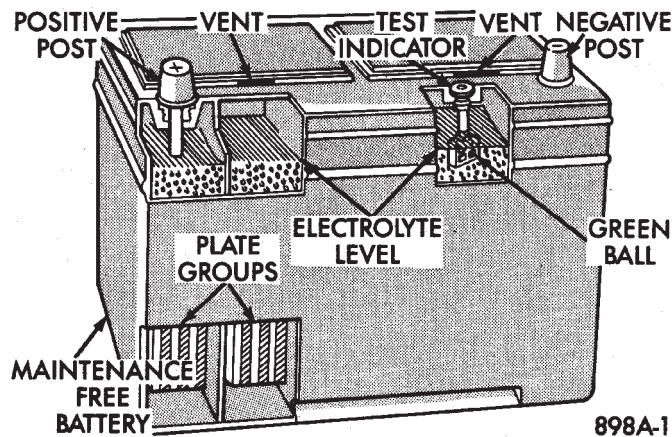

Fig. 1 Maintenance Free Battery—Typical

Factory installed batteries (Fig. 1) do not have removable battery cell caps. Water cannot be added to factory installed battery. Battery is sealed, except for small vent holes in the top. Chemical composition inside the battery produces an extremely small amount of gases at normal charging voltages. The factory installed battery is equipped with a test indicator (Fig. 1) that displays a colored ball to show battery state-of-charge.

- Green Indicator = Full charge
- Black Indicator = Discharged
- Yellow Indicator = Battery replacement required.

BATTERY VISUAL INSPECTION AND SERVICE

- (1) Make sure ignition switch is in OFF position and all accessories are OFF.
- (2) Disconnect and remove the battery terminals from the battery posts. Remove battery negative cable first (Fig. 2).

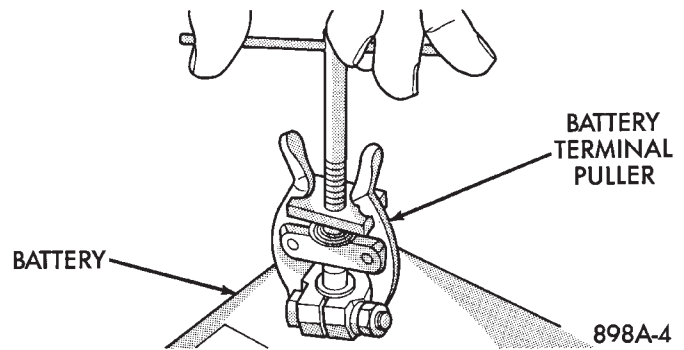

Fig. 2 Remove Battery Cables

WARNING: TO PROTECT THE HANDS FROM BATTERY ACID, A SUITABLE PAIR OF HEAVY DUTY RUBBER GLOVES, NOT THE HOUSEHOLD TYPE, SHOULD BE WORN WHEN REMOVING OR SERVICING A BATTERY. SAFETY GLASSES ALSO SHOULD BE WORN.

- (3) Remove battery hold down clamp (Fig. 3) and remove battery from vehicle.

CAUTION: Do not allow baking soda solution to enter vent holes, as damage to battery can result.

- (4) Clean top of battery with a solution of warm water and baking soda. Apply solution with a bristle brush and allow to soak until acid deposits loosen (Fig. 4). Rinse with clear water and blot dry with paper toweling. Dispose of toweling in a safe manner. Refer to the WARNINGS on top of battery.

- (5) Inspect battery case and cover for cracks or leakage. If leakage is present battery must be replaced.

- (6) Inspect battery tray (Fig. 3) for damage caused by acid from battery. If acid damage is present, it will be necessary to clean area with same solution described in Step (4).

- (7) Clean battery posts with a suitable battery post cleaning tool (Fig. 5).

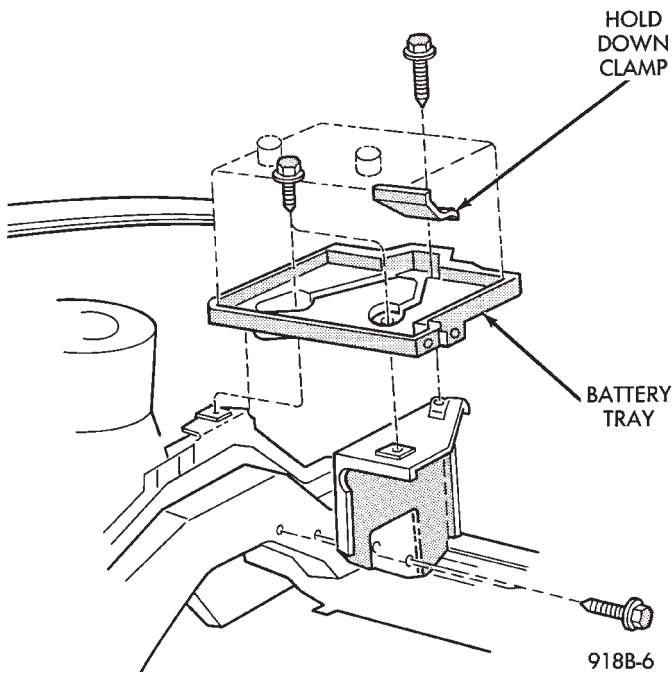

Fig. 3 Battery Hold-Down/Tray

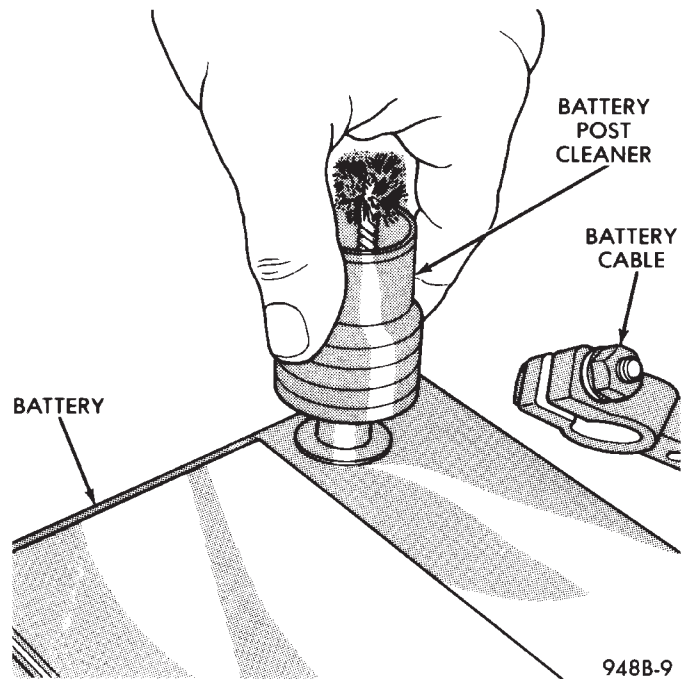

Fig. 5 Cleaning Battery Posts

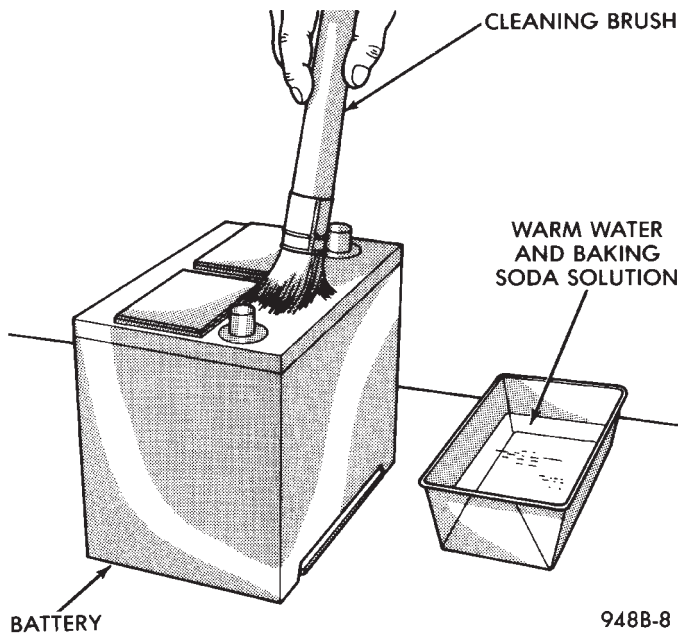

Fig. 4 Cleaning Battery

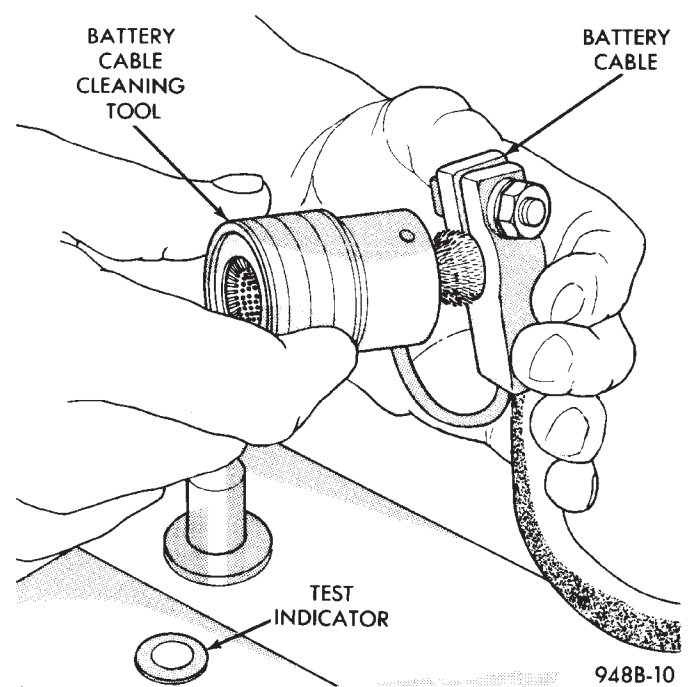

Fig. 6 Cleaning Battery Cable Terminal

(8) Clean inside surfaces of battery terminal clamps with a suitable battery terminal cleaning tool (Fig. 6). Replace damaged or frayed cables and broken terminal clamps.

(9) Inspect battery for proper or damaged hold down ledge.

(10) Install battery in vehicle making sure that battery is properly positioned on battery tray (Fig. 3).

(11) Install battery hold down clamp, making sure that it is properly positioned on battery.

(12) Place felt grease washer onto battery positive post.

(13) Connect battery cable clamps to battery posts making sure top of clamp is flush with top of post. Install POSITIVE cable first.

(14) Tighten clamp nuts securely.

STARTER

INDEX

	page		page
General Information	3	Starter Motor Replacement	3
Neutral Starting and Back-Up Switch	7	Starting System	3
Starter Component Replacement	5	Supply Circuit and Control Circuit	3

GENERAL INFORMATION

This section will cover STARTER replacement and service procedures only. For starter diagnostic procedures, refer to Group 8A, Battery/Starting/Charging Systems Diagnostics.

STARTING SYSTEM

The starting system has:

- Ignition switch
- Starter relay
- Neutral starting and back up switch
- Wiring harness
- Battery
- Starter motor with an integral solenoid

BOSCH STARTERS

Bosch permanent magnet starter motor is available on 2.5L and 3.0L engines on all vehicles. A planetary gear train transmits power between starter motor and pinion shaft. The fields have six permanent magnets.

NIPPONDENSO STARTERS

- A Nippondenso reduction gear-field coil starter motor is available on 3.0L, and 3.3L engines.

SUPPLY CIRCUIT AND CONTROL CIRCUIT

Both starter systems consists of two separate circuits:

- A high amperage supply to feed the starter motor.
- A low amperage circuit to control the starter solenoid.

For additional information on starter motor supply and control circuits, refer to Group 8A, Battery/Starting/Charging Systems Diagnostics.

STARTER MOTOR REPLACEMENT

BOSCH STARTER 2.5L ENGINE

- (1) Disconnect battery negative cable (Fig. 1).
- (2) Raise vehicle.
- (3) Remove heat shield clip from the starter and heat shield (Fig. 2). For easier servicing, do not remove the wiring from starter at this time.
- (4) Remove two bolts and one nut attaching starter to engine (Fig. 3).

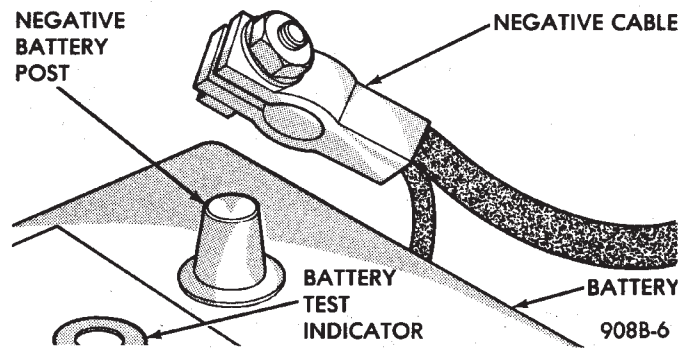

Fig. 1 Remove or Install Battery Cable

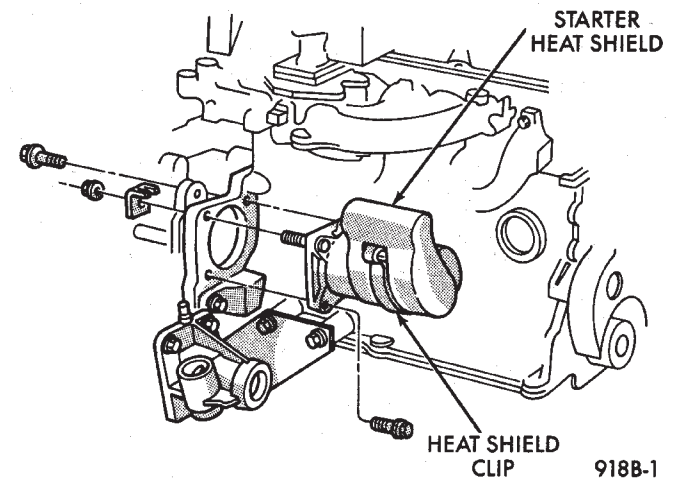

Fig. 2 Starter Heat Shield—4 Cylinder Engines

(5) Remove starter/starter solenoid assembly from engine. Position the starter to gain access to the wiring connectors.

(6) Disconnect the battery positive cable and wiring at the starter.

(7) Remove the starter from vehicle.

(8) For installation, reverse above procedures. Clean corrosion/dirt from the cable and wire terminals before installing wiring to the solenoid.

BOSCH OR NIPPONDENSO STARTER—3.0L OR 3.3L ENGINE

- (1) Disconnect battery negative cable (Fig. 1).
- (2) Raise vehicle.
- (3) Remove three starter attaching bolts from engine/transaxle (Fig. 4).

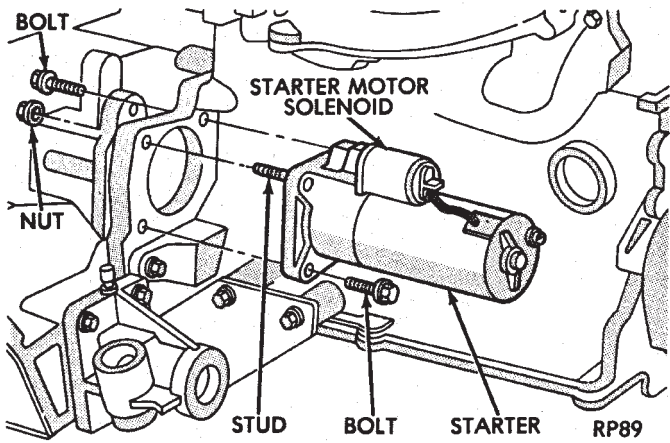

Fig. 3 Bosch Starter—2.5L Engine

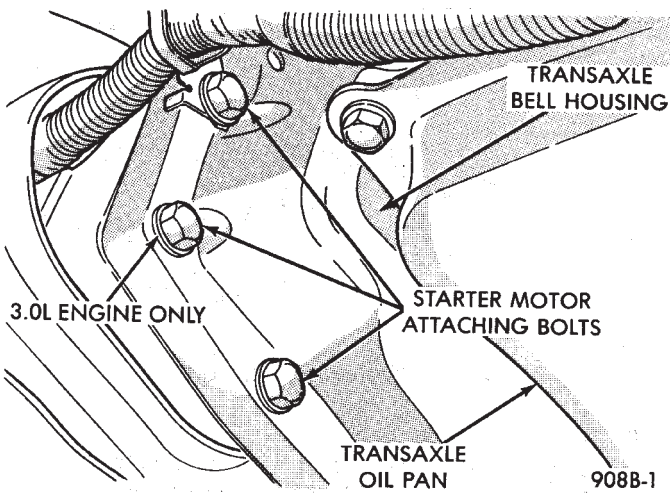
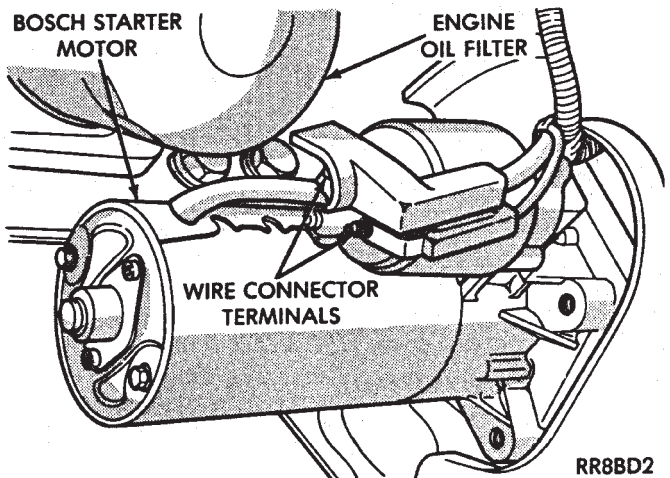

Fig. 4 Remove or Install Attaching Bolts

(3) Remove two wire connector terminal nuts and remove connector (Bosch, Fig. 5) (Nippondenso, Fig. 6 or 7).



RR8BD2

Fig. 5 Wire Terminal Connections—Bosch Starter

(4) Remove starter from vehicle (Bosch, Fig. 8) (Nippondenso, Fig. 9).

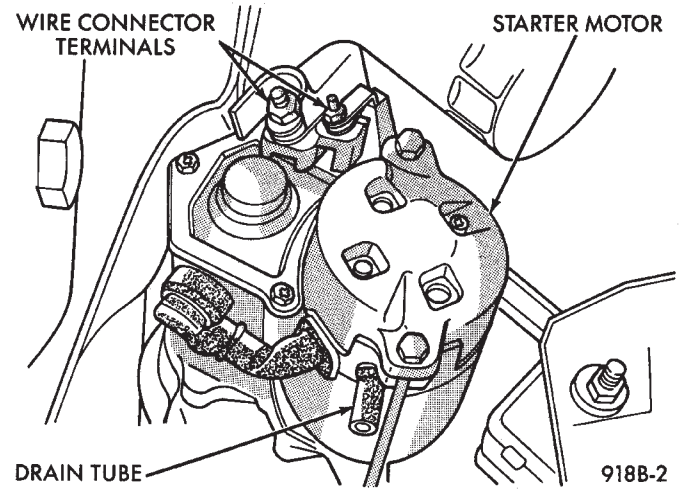

918B-2

Fig. 6 Wire Terminal Connections—3.0L Engine—Nippondenso Starter

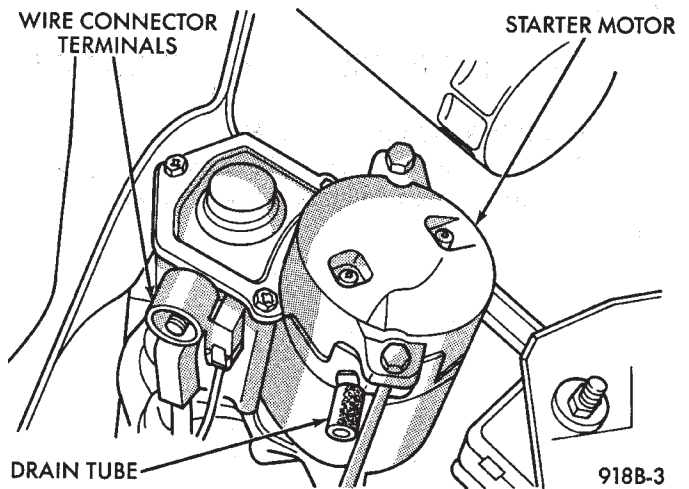

918B-3

Fig. 7 Wire Terminal Connections—3.3L Engine—Nippondenso Starter

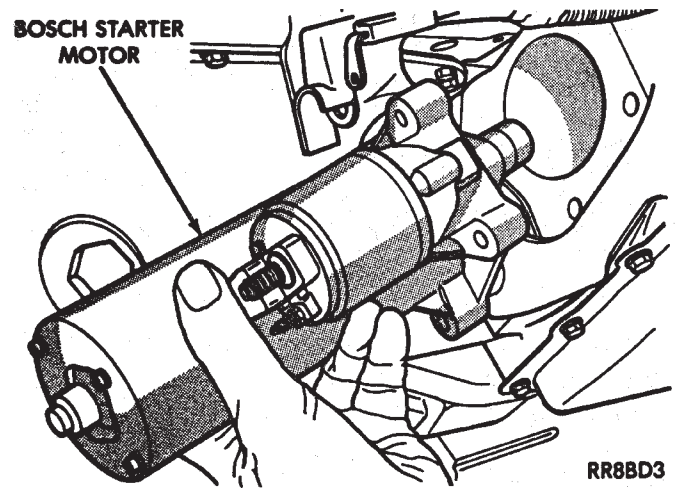

RR8BD3

Fig. 8 Remove/Install Starter—Bosch—Typical

(5) For installation, reverse above procedures. Clean corrosion/dirt from the cable and wire terminals before installing wiring to the solenoid.

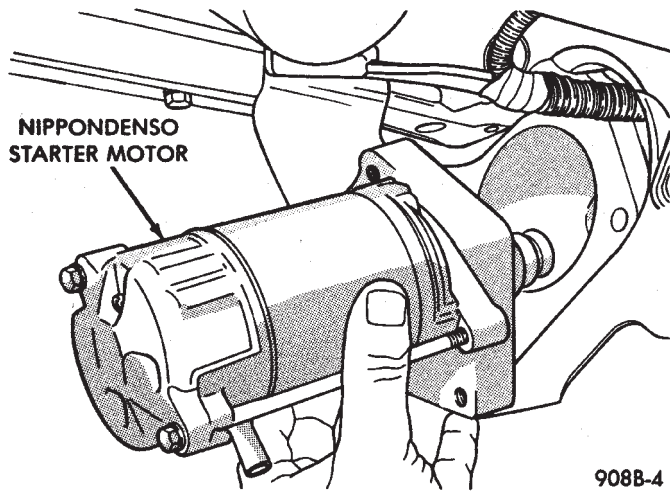

Fig. 9 Remove/Install Starter—Nippondenso—Typical

STARTER COMPONENT REPLACEMENT

Caution: When servicing the starter assembly off the vehicle, do not clamp the starter to a vice. Internal damage may result.

NIPPONDENSO STARTER GEAR AND CLUTCH

(1) Remove the two gear housing attaching screws and separate the gear housing from the solenoid housing (Fig. 10). The pinion gear, pinion gear bearing, and drive gear will be loose between the solenoid housing and gear housing (Fig. 11). When reinstalling pinion gear and bearing, wipe with a clean rag and coat with lightweight high temperature wheel bearing grease. Place the lubricated bearing and gear over bearing shaft in the gear housing (Fig. 12).

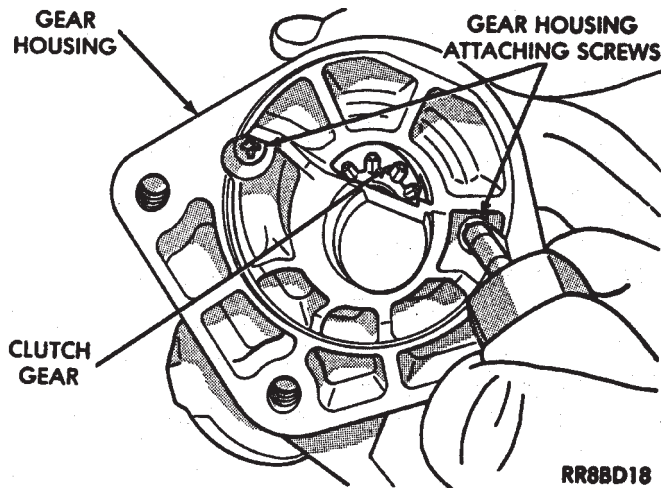

Fig. 10 Remove or Install Gear Housing

(2) Remove the starter gear and clutch assembly from the solenoid housing (Fig. 13).

(3) For installation, reverse above procedures.

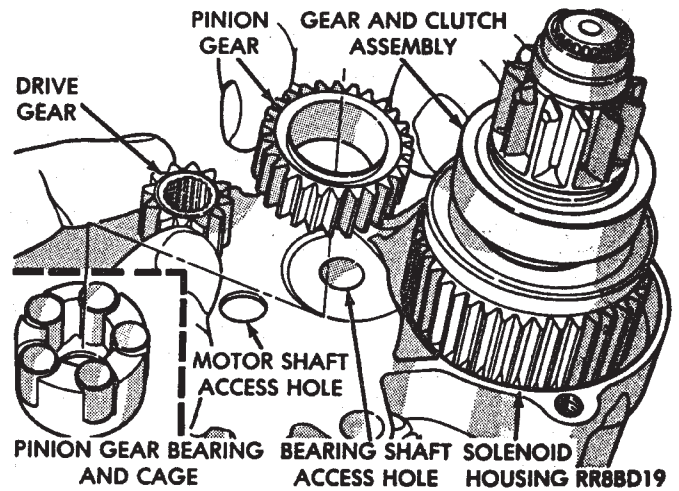

Fig. 11 Remove or Install Drive and Pinion Gears

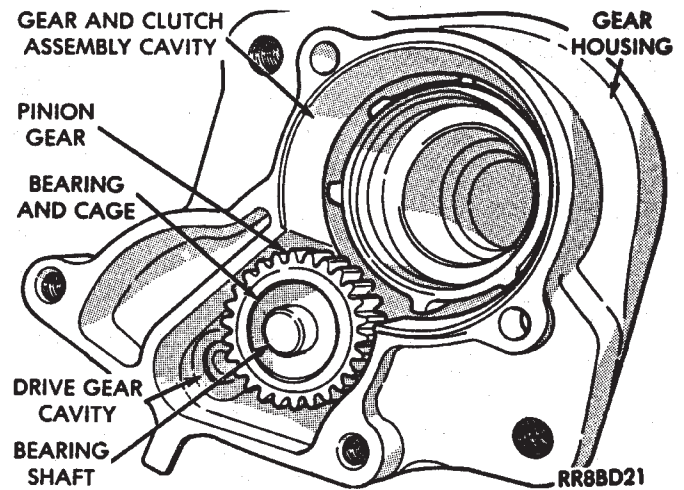

Fig. 12 Lubricate and Install Pinion Gear Bearing

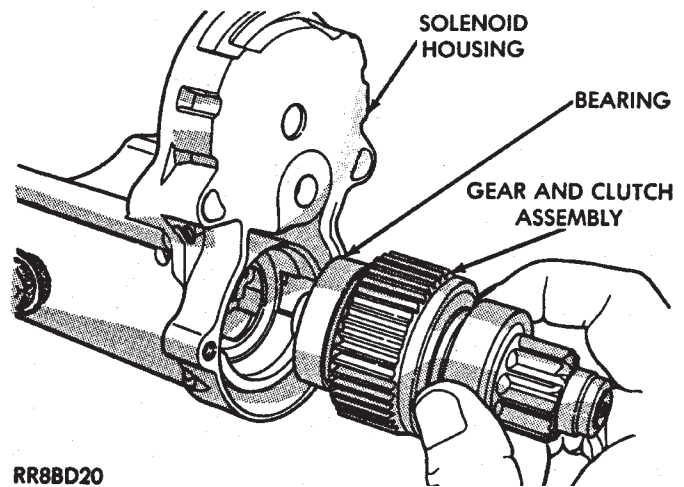

Fig. 13 Gear and Clutch Assembly



BOSCH STARTER SOLENOID

(1) Remove field terminal nut (Fig. 14).

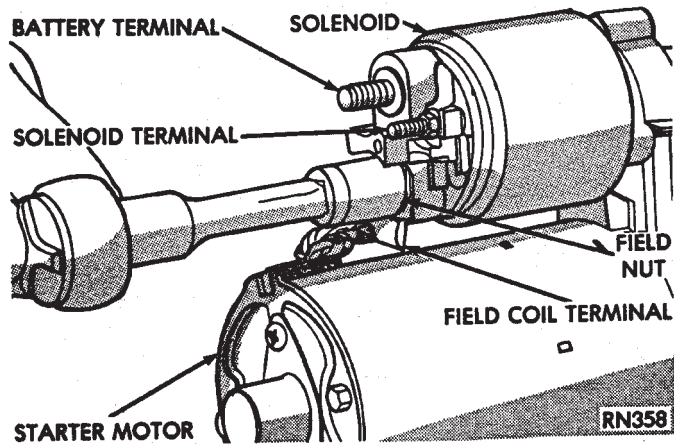

Fig. 14 Field Terminal Nut

(2) Remove field terminal (Fig. 15).

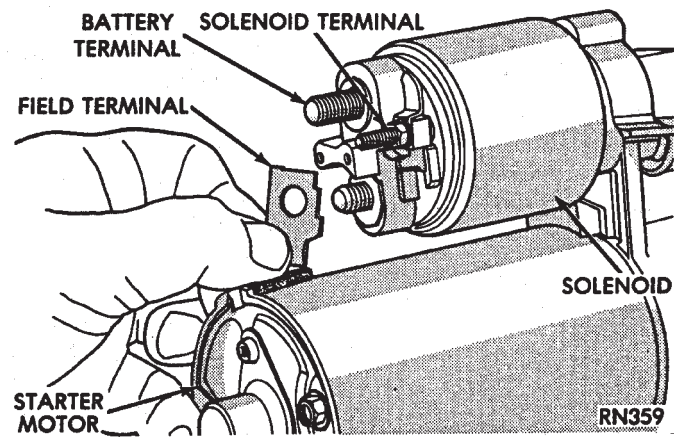

Fig. 15 Field Coil Terminal

(3) Remove field washer (Fig. 16).

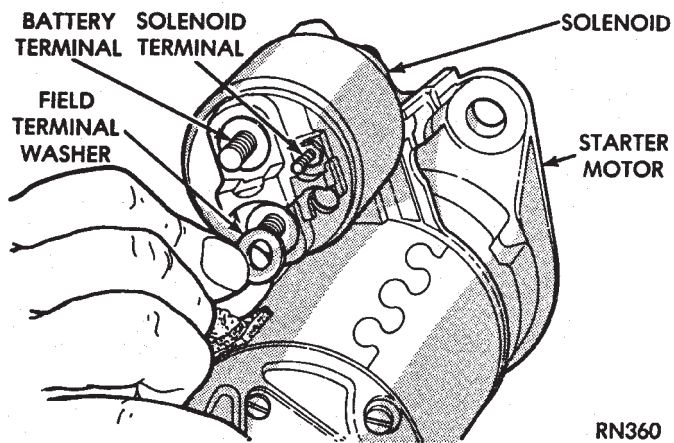

Fig. 16 Field Terminal Washer

(4) Remove three solenoid mounting screws (Fig. 17).

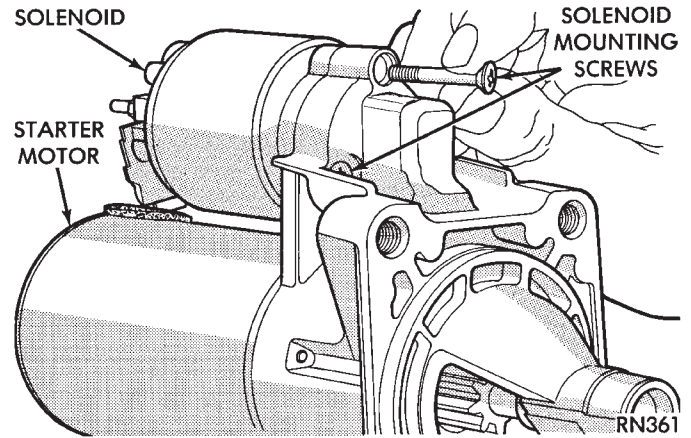

Fig. 17 Solenoid Mounting Screws

(5) Remove the solenoid from the starter assembly.

(6) For installation, reverse above procedures.

BOSCH STARTER GEAR AND CLUTCH

(1) Remove solenoid assembly (Fig. 18).

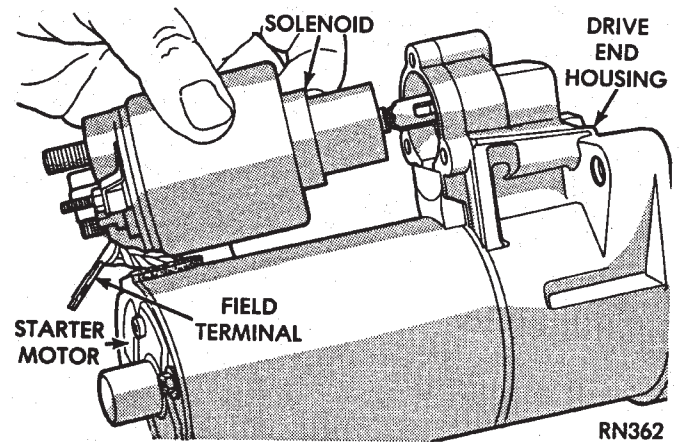

Fig. 18 Solenoid

(2) Remove the two through-bolts securing the starter drive end housing to the motor housing (Fig. 19) and separate housings.

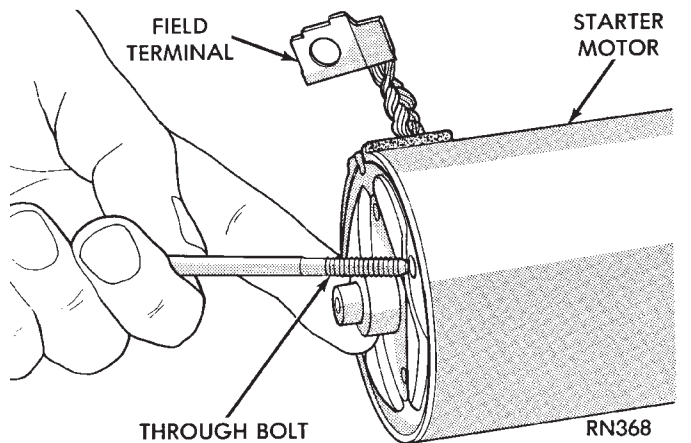

Fig. 19 Through-Bolt

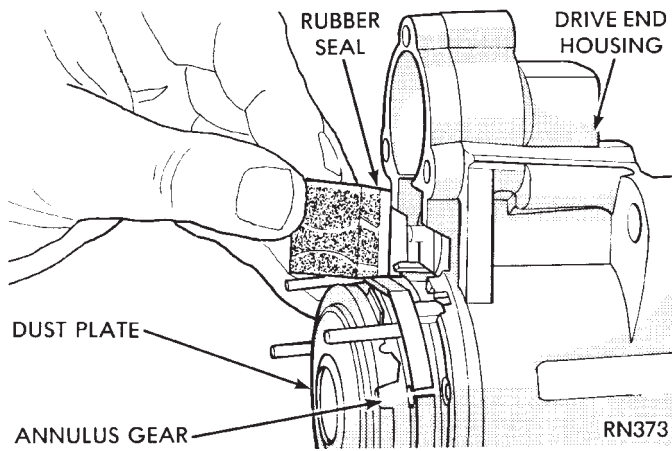

Fig. 20 Rubber Seal

- (3) Remove rubber seal (Fig. 20).
- (4) Pull the gear and clutch assembly from the drive end housing (Fig. 21).
- (5) For installation, reverse above procedures.

NEUTRAL STARTING AND BACK-UP SWITCH

For electrical diagnostics, when checking the starter circuits, refer to the STARTER RELAY TESTS chart in Group 8A, Battery/Starting/Charging Systems Diagnostics.

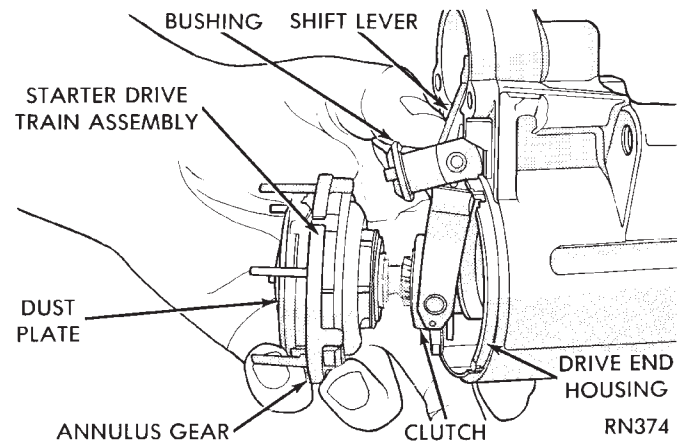

Fig. 21 Starter Drive Gear Train

For removal and installation of switch, refer to Neutral Starting and Back-up Switch Replacement in Group 21, Transaxle.

GENERATOR

INDEX

	page		page
General Information	8	Generator Replacement—3.0L Engine	9
Generator Replacement—2.5L Engine	8	Generator Replacement—3.3L Engine	9

GENERAL INFORMATION

This section will cover generator replacement only. Information covering generator on-vehicle testing and diagnosis can be found in Group 8A, Battery/Starting/Charging Systems Diagnostics. To identify the generator, refer to the Generator Specification chart at the rear of this section.

These generators are not intended to be disassembled for service. It must be replaced as an assembly.

GENERATOR REPLACEMENT—2.5L ENGINE

Removal and repositioning of A/C Compressor without disconnecting refrigerant lines is necessary on some models to gain access to generator.

- (1) Disconnect battery negative cable (Fig. 1).

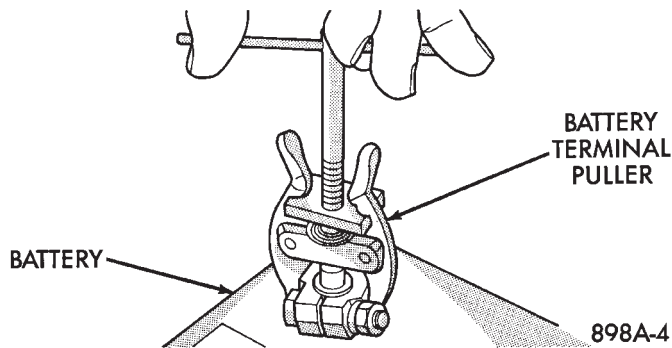

Fig. 1 Remove battery negative cable

- (2) If Equipped With air conditioning:
 - (a) Remove the A/C drive belt. Refer to Group 7, Cooling System.
 - (b) Remove the four bolts retaining the A/C compressor to the mounting bracket (Fig. 2).
 - (c) Do not disconnecting the A/C refrigerant lines, position the A/C compressor to allow generator removal.

WARNING: THE A/C REFRIGERANT SYSTEM IS UNDER PRESSURE EVEN WHEN THE ENGINE IS OFF. REFER TO THE SAFETY PRECAUTIONS AND WARNINGS SECTION IN HEATING AND A/C, GROUP 24, BEFORE PERFORMING ANY SERVICE OPERATION.

- (3) Remove the generator drive belt. Refer to Group 7, Cooling System.

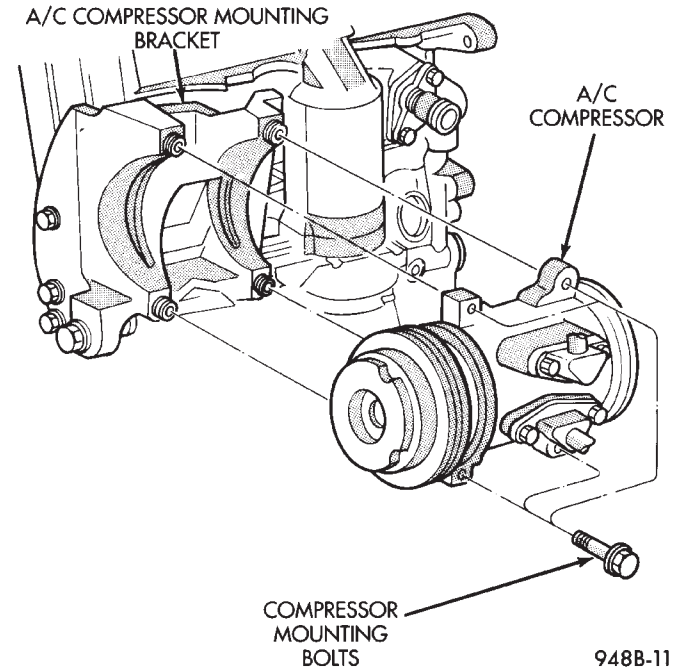

Fig. 2 A/C Compressor Removal and Installation—2.5 L Engine

- (4) Remove the two generator mounting bolts (Fig. 3) and position the generator to gain access to all the wire connectors. If equipped with:

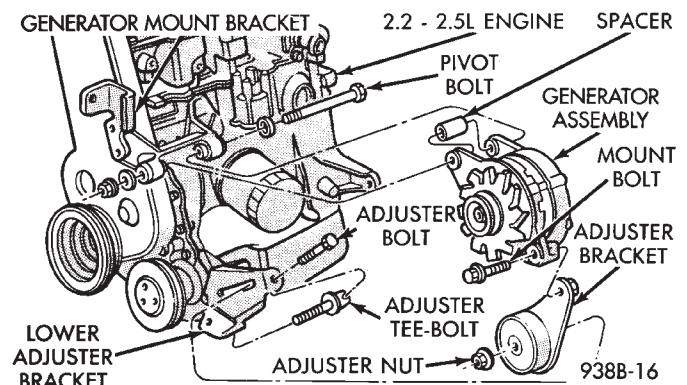

Fig. 3 Remove or Install Mounting Bolts

- BOSCH GENERATOR. Remove B+ terminal nut, field terminal nuts, and ground harness hold down nuts (Fig. 4). Remove wire connector assembly.
- NIPPONDENSO GENERATOR. Remove nuts from field terminals, ground terminal, wire harness and

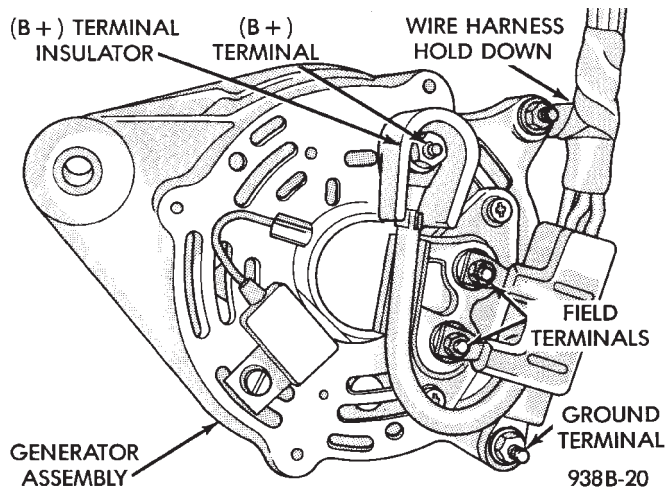

Fig. 4 Remove or Install Wire Connector Assembly—Bosch Generator

B+ terminal (Fig. 5). B+ terminal nut must be removed last to prevent damage to terminal insulator.

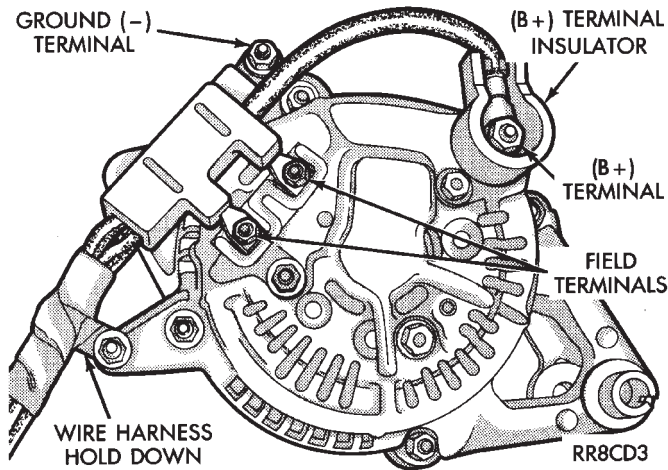

Fig. 5 Remove or Install Wire Connector Assembly—Nippondenso Generator

(5) Remove the generator from the vehicle.
 (6) For installation, reverse above procedures. Tighten all fasteners to the proper torque. Refer to the Torque Specifications chart at the rear of this group.

GENERATOR REPLACEMENT—3.0L ENGINE

- (1) Disconnect battery negative cable (Fig. 1).
- (2) Remove generator drive belt. Refer to Group 7, Cooling System.
- (3) Remove the generator mounting bolts and separate the generator from the mounting bracket (Fig. 6).
- (4) Remove the B+ terminal nut, field terminal nuts, and ground/wire harness hold-down nuts. Remove wire connectors.
- (5) Remove the generator from the vehicle.

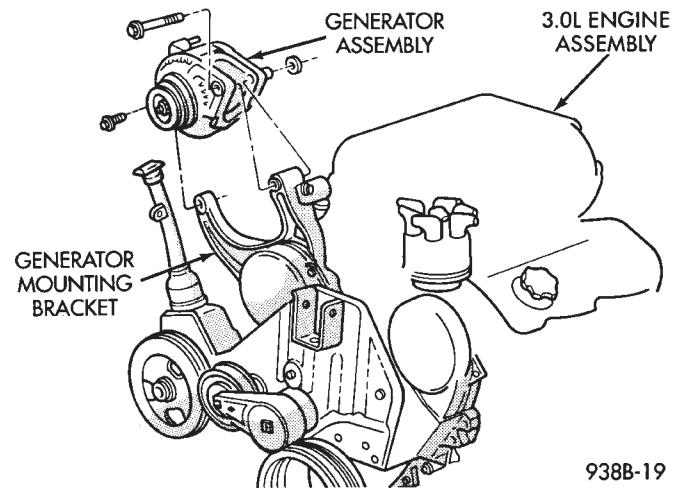

Fig. 6 Remove or Install Generator Mounting Bolts—3.0L Engine

(6) For installation, reverse above procedures. Tighten all fasteners to the proper torque. Refer to the Torque Specifications chart at the rear of this group.

GENERATOR REPLACEMENT—3.3L ENGINE

- (1) Disconnect battery negative cable (Fig. 1).
- (2) Remove generator drive belt. Refer to Group 7, Cooling System.
- (3) Loosen, but do not remove the nut on the support bracket at exhaust manifold (Fig. 7).

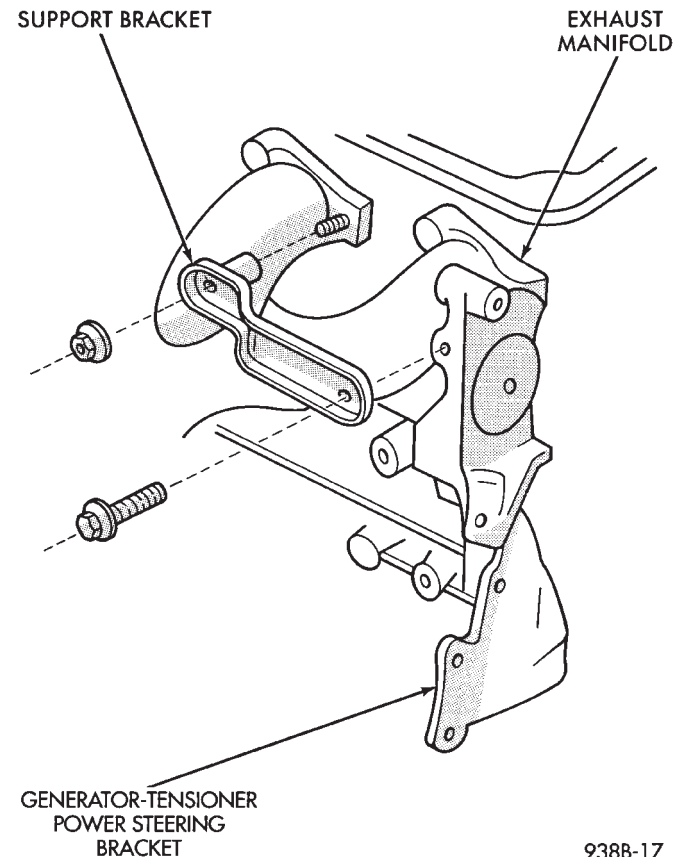

Fig. 7 Support Bracket for Generator Tensioner Power Steering Bracket

(4) Remove the generator tensioner power steering bracket bolt.

(5) Remove the tensioner stud nut and the tensioner (Fig. 8).

(6) Remove the generator mounting bolts.

(7) Remove and position the power steering reservoir from the generator mounting bracket. Do not remove the hoses from the reservoir.

(8) Remove the three generator support bracket bolts (Fig. 7).

(9) Remove intake plenum-to-generator mounting bracket bolt.

(10) Remove generator support bracket (Fig. 8).

(11) Position generator and remove generator wiring.

(12) Remove generator.

(13) For installation, reverse above procedures. Tighten all fasteners to the proper torque. Refer to the Torque Specifications chart at the rear of this group.

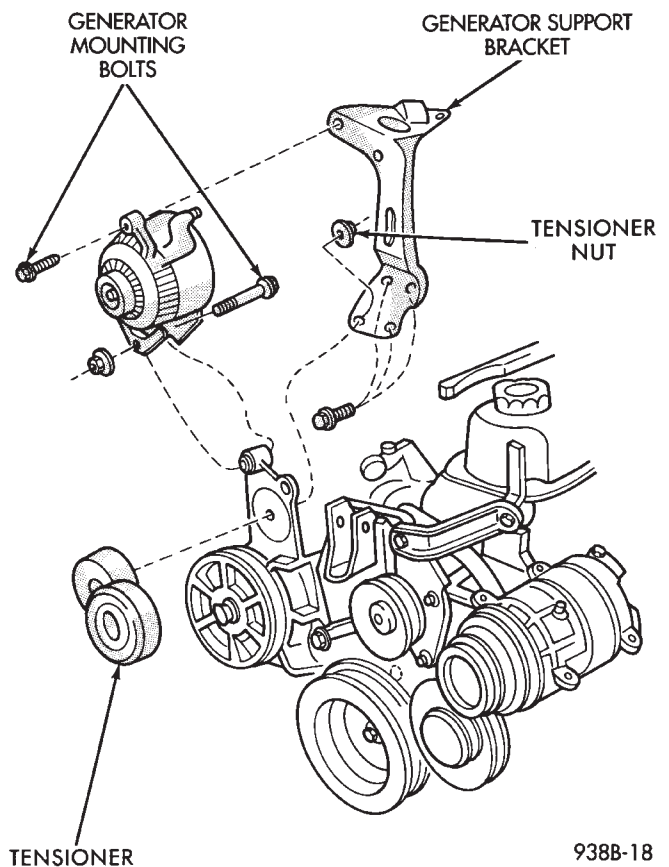

938B-18

Fig. 8 Generator/Support Bracket—3.3L Engine

SPECIFICATIONS
STARTER/BATTERY

STARTER				
Manufacturer	Nippondenso		Bosch	
Engine Application	3.0L/3.8L	3.3L	3.0L	2.2-2.5L
Part Number and Power Rating	1.4 Kw	1.2 Kw	1.1 Kw	1.1 Kw
Voltage	12	12	12	12
No. of Fields	4	4	Permanent Magnet	
No. of Poles	4	4	6	6
Brushes	4	4	4	4
Drive	Conventional Gear Train	Conventional Gear Train	Planetary Gear Train	Planetary Gear Train
Free Running Test				
Voltage	11	11	11	11
Amperage Draw	73 Amps	73 Amps	73 Amps	69 Amps
Minimum Speed RPM	3601 RPM	3401 RPM	3473 RPM	3447 RPM
Solenoid Closing Voltage	7.5 Volts	7.5 Volts	7.5 Volts	7.5 Volts
Cranking Amperage Draw Test	150-220 Amps*	150-200 Amps*	150-220 Amps*	

*Engine should be up to operating temperature. Extremely heavy oil or tight engine will increase starter amperage draw.

BATTERY		
Load Test (Amps)	Cold Cranking Rating @ 0°F	Reserve Capacity
200 Amp	500 Amp	110 Minutes
250 Amp	600 Amp	120 Minutes
315 Amp	685 Amp	125 Minutes

CRANKING RATING is the current a battery can deliver for 30 seconds and maintain a terminal voltage of 7.2 volts or greater at specified temperature.

RESERVE CAPACITY RATING is the length of time a battery can deliver 25 amps and maintain a minimum terminal voltage of 10.5 volts at 27°C (80°F).

928A-10

GENERATOR AMPERAGE/IDENTIFICATION NUMBERS

TYPE	**CASE I.D. TAG NUMBER	PULLEY GROOVES	ENGINE USAGE	* AMPERAGE OUTPUT
BOSCH 90 HS	4557431	4	2.5L	84 AMP
DENSO 90 HS	5234031	4	2.5L	86 AMP
DENSO 90 HS	5234032	6	3.0L-3.3L	90 AMP
DENSO 120 HS	5234208	4	2.5L	98 AMP
DENSO 120 HS	5234033	6	3.0L-3.3L	102 AMP

*WITH GENERATOR FULL FIELD AT 1250 RPM

**CASE I.D. TAG NUMBER IS LOCATED ON BOTTOM OF GENERATOR CASE

938A-89



TORQUE SPECIFICATIONS

Description	Torque
Generator Mounting Bolts	
2.2L/2.5L Engine	54 N•m (40 ft. lbs.)
3.3L/3.8L Engine	54 N•m (40 ft. lbs.)
3.0L Engine—Upper Bolt	54 N•m (40 ft. lbs.)
Lower Bolt	54 N•m (40 ft. lbs.)
Generator Field Terminal	
Nuts	3 N•m (25 in. lbs.)
Generator B+ Terminal and	
Ground Terminal Nuts	9 N•m (75 in. lbs.)
Battery Hold Down Clamp Bolt	14 N•m (125 in. lbs.)
Starter Mounting Bolts/Nuts	54 N•m (40 ft. lbs.)

938A-88